



PLANTER



A - Patented one-form technology and ANSI-BIFMA X5.3-2007 certified

B - Adjustable floor levelers

C - Interchangeable key lock and barrel system

D - Adjustable slotted shelves with ?? Capacity

E - Fennel tambour door system with Aluminum slammer rails and magnetic strip

F - Environmentally friendly with 30% recycled raw material

G – Subtle premium powder coat finish

3 x 200mm Dia cut outs
For self watering pots
(lift off top panel)

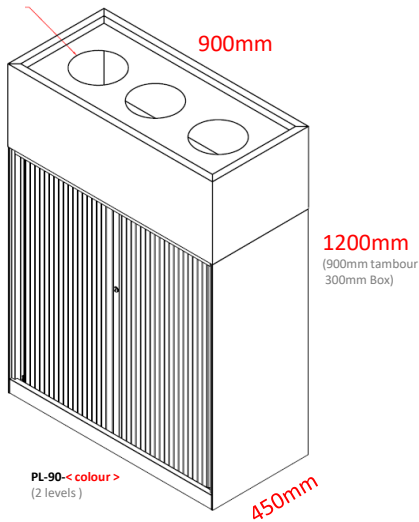

3 x 200mm Dia cut outs
For self watering pots
(lift off top panel)

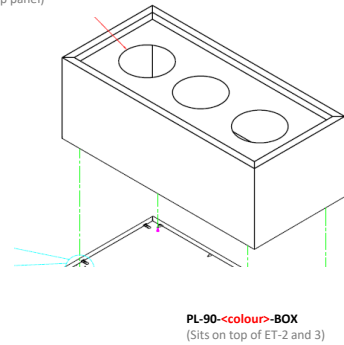

Options:

- Specified Powder coat to full unit
- Melamine bench top
- Extra Shelves (ET-SHELVES <colour>.900W)
- Metal dividers to slot into shelves (SD-WHITE/PSP)
- Pull out A4 file rack POF-9-BLK (1 ONLY ON PL-90)

Premium power coat finish available stockexpress.®



PL-90-W
(Pearl white)



PL-90-PSP
(Preclus silver pearl)



PL-90-B
(Satin black)

